

A Method to Characterise the Propensity for Dynamic Sagging of Weight Materials in Drilling Fluids

Bjarne Aas¹, Antonino Merlo², Rolv Rommetveit³ and Njål Sterri⁴

¹RF-Rogaland Research, Stavanger Norway. ²ENI-Agip SpA, Italy.

³SINTEF, Bergen, Norway. ⁴Telemark University College, Norway.

ABSTRACT

Powder size particles mixed into polymer fluids with two or three-parametric power law rheology may precipitate in the quiescent fluid very slowly, due to the very high viscosity in the fluid at low shear rates. They will normally settle much faster if the fluid is subjected to horizontal shear flow. This article describes a method to measure particle settling velocities in horizontal, laminar shear flow at a constant shear rate. The method may particularly find application in classifying drilling fluids used in the oil industry, where losing weight material from the fluid during drilling of inclined or horizontal oil or gas wells sometimes can create severe operational problems.

INTRODUCTION

When drilling an oil or gas well one of the main functions of the drilling fluid is to maintain proper pressure balance in the well. I.e., the hydrostatic pressure in the well should be sufficiently large to prevent influx of fluids from a gas or oil-bearing formation into the bore hole, but not so large that the formation is forced open and the drilling fluid is lost to the formation. This operational window is sometimes quite narrow, especially for deep wells. The pressure balance is in most cases achieved by adding varying amounts of powdered weight material to the drilling fluid. The weight material may typically consist of finely ground barite (BaSO_4), with specific

density 4.5 and particle diameters around 20 μm to 70 μm .

Since the powdered weight material is much denser than the base fluid (e.g. water or oil), it will tend to settle out of the suspension during use. Most modern drilling fluids are composed to form gels and keep the weight material suspended at static conditions, although in some cases even this may be difficult to achieve. However, all fluids will sag under dynamic conditions, i.e. under shear flow. Turbulence will have some re-suspending action, but a sufficient degree of turbulence can not always be sustained in drilling operations. In laminar or weakly turbulent flow sagging of weight material can often complicate the maintaining of proper pressure balance, especially in long wells with an inclination close to horizontal.

Accordingly, there has been some research activity on the subject in connection with the drilling of gas and oil wells. Initially one concentrated on static sagging¹, but one soon realized that dynamic sagging was as important^{2,3}. Jefferson developed a method somewhat similar to the one described here, using a cylindrical rheometer and sampling fluid from the bottom of the rheometer cup after given times³. Bern et al.⁴ suggest (1996) that the expertise to control static sagging in oil wells exists, but dynamic sagging is not well understood. The rheology at very low shear rates is important for keeping the particles

suspended during static conditions. Some researchers claim that the rheology at very low shear rates is important for sagging also at dynamic conditions⁵. Measurements seem to give positive correlations for some drilling fluids. Some theoretical considerations have been put forward to explain the behaviour⁶, but a proper theoretical understanding seems to be lacking.

RF-Rogaland Research has developed a method to characterize the propensity of fluids with respect to dynamic sagging, using relatively standard laboratory cylindrical rheometers. An advantage with the method is that one here can study the sagging process at a well defined fluid shear rate. This paper describes the measurement method, and gives some examples of measurements on non-linear polymer fluids. In this work only sagging at shear rates larger than about 100 s⁻¹ have been investigated.

PRINCIPLE OF MEASUREMENT

A cylindrical, constant shear stress rheometer was used for the measurements. The fluid with suspended particles experiences a horizontal shear flow in the cylindrical space between stator and rotor. As the gap between stator and rotor is quite small (see Figure 1), the shear rate is practically constant over the shear flow volume. As the weight material sags out vertically and settles in the space below the rotor the viscosity of the fluid remaining between stator and rotor will normally decrease. The time development of the average viscosity of the fluid left in the shear volume provides a measure for the sagging velocity of the particles in the fluid.

EXPERIMENTAL ARRANGEMENT

Most of the sagging measurements were performed with the loggable Carri-Med CS50 laboratory rheometer at room temperature. In this cylindrical rheometer a constant shear stress is applied to the fluid and the resulting shear rate is logged as a function of time. Typical dimensions of the system used in the

tests are shown in Figure 1. The bottom surface of the rotor is hollowed out, to form an air pocket. This is done in order to minimize drag from the fluid or sagged-out material on the bottom surface of the rotor. The rotor was made of hard plastic and the stator of stainless steel.

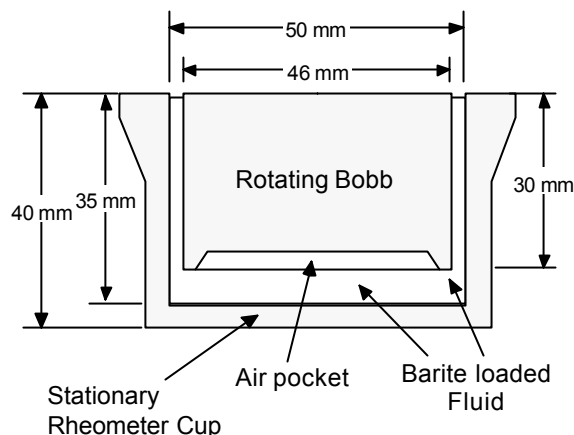

Figure 1. Rheometer rotor and stator used in the sagging measurements.

Figure 2 gives an example of a sag measurement on a xanthan gum solution loaded with 576 g/l barite.

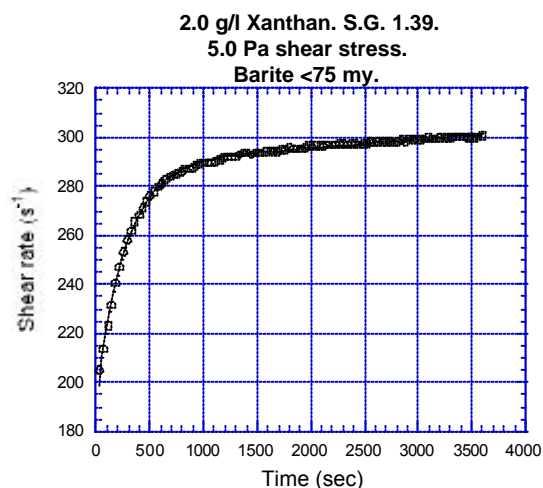

Figure 2. Sag measurement on a xanthan gum solution.

In the initial phase of the project a rheometer cup with narrow vertical channels in the side

wall was used (Figure 3). Rotor and cup were made of hard plastic (PET). Small amounts of fluid could be sampled from the shear flow volume through the channels with a syringe.

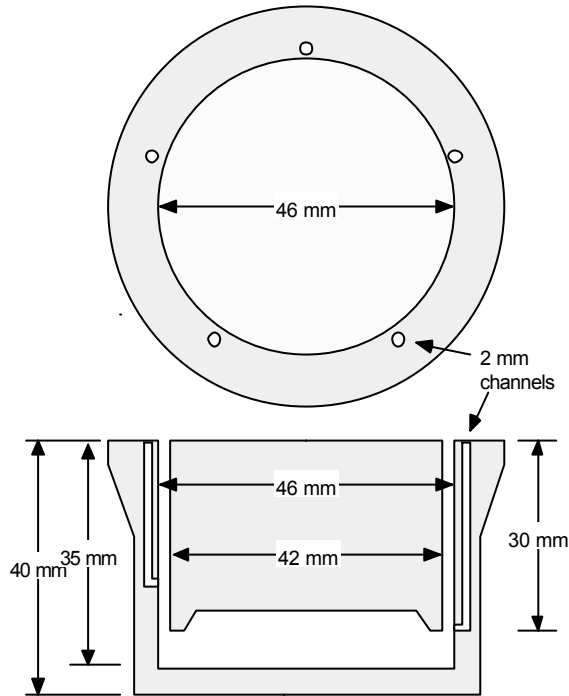

Figure 3. Rotor and stator used for sampling of fluid.

With this rheometer cup the sagging process in the shear flow volume between stator and rotor could be closer investigated. The channels reached to depths of 7, 14, 21, 27 and 33 mm in the 35 mm deep cup. Figure 4 shows a measurement series on a xanthan solution, loaded with 576 g/l barite. After measuring times indicated by the end of each curve samples were extracted and their density was determined. Figure 5 shows a measurement with screened barite, using particles with sizes between 25 μm and 45 μm . As can be seen from the figure, all particles do not settle with the same velocity, even if they have fairly uniform sizes. There seems to be some degree of vertical mixing in addition to the precipitation.

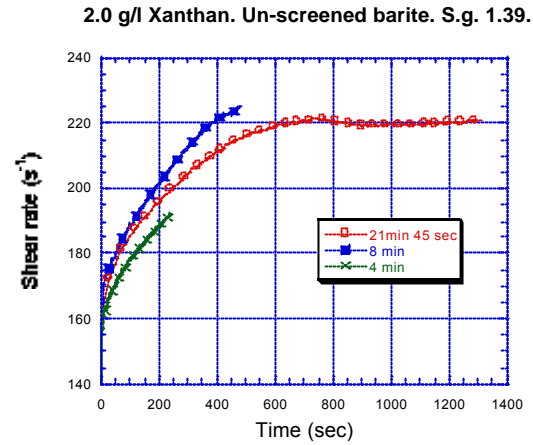

Figure 4. Initial sag measurement investigations.

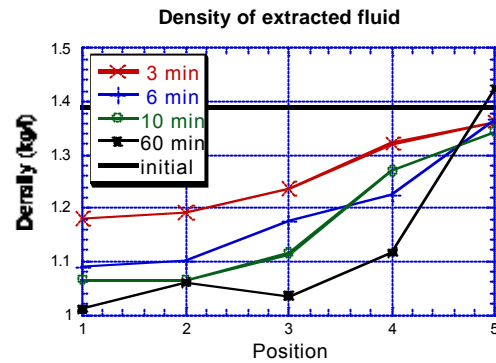

Figure 5. Density of sampled fluid at different positions in the rheometer cup.

ANALYSIS OF THE MEASUREMENTS

A typical sagging measurement is shown in Figure 2. The small circles are measurements, the solid line is a curve fit. Many of the measurements could be well fitted with an exponential function under a linear curve:

$$\dot{g} = a_1 - a_2 \cdot \exp(-t/t_0) + t \cdot a_3 \quad (1)$$

with: \dot{g} = shear rate (s^{-1})
 t = measuring time (s)
 a_2 = difference in shear rate before and after sagging (s^{-1})
 t_0 = sagging time constant (s)

a_3 represents a slowly increasing linear baseline, due to a slow evaporating of the fluid out of the rheometer during long measurements.

It became after some time clear, that the sagged-out slurry under the rotating bob in many cases was hindering the movement of the rotor, resulting in a too low rotation rate for the bob. One may, however, assume that this dragging effect starts only after some time, when enough particles have settled down. Therefore, only the slope of the curve at the beginning of a measurement was used in the analysis. The final, constant shear rate which follows after all particles have settled out was calculated from the viscosity curve measured on the fluid without barite.

t_0 , the sagging time constant, will be dependent on the height, H , of the shear flow volume between stator and rotor. The larger this height, the longer it will take for the particles to sag out. However, by normalizing the sagging time constant with this height one can define an instrument independent sagging velocity:

$$v_s = \frac{H}{t_0} \quad (2)$$

This is only an approximation to the actual average settling velocity at the start of the measurement. With a constant shear stress rheometer the shear rate increases over time and one would, among other, have to correct for the viscosity change in the base fluid with increasing shear rate in order to obtain a better value for the actual settling velocity.

From the results of the measurements on the polymer fluids the following general statements could be made:

- Sagging velocity decreases with particle loading.
- Sagging velocity increases with particle size.

At constant particle loading:

- Sagging velocity is approximately proportional to the shear rate.

- Sagging velocity is approximately inversely proportional to the fluid viscosity at the pertinent shear rate.

Based on the above observations, a parameter which roughly characterizes a polymer fluid's propensity for sagging can be defined. We have defined a *sagging index* as:

$$S.I. = \frac{H}{t_0} \frac{\eta_{start} + \eta_{end}}{\dot{\gamma}_{start} + \dot{\gamma}_{end}} \quad (3)$$

I.e., the sagging velocity, v_s , is normalized with the average shear rate ($\dot{\gamma}$) and the average viscosity (μ) at the beginning and the end of the measurement. It is a parameter with which one in a relatively simple way can compare the sagging process in different fluids.

FLUIDS AND PARTICLES

In the sagging tests fluids with different properties were investigated. These include silicon oil, CMC solutions, xanthan gum solutions and a series of different drilling fluid formulations.

The silicon oil was a Dow Coring 200 type with bulk viscosity of 50 cS. It has a Newtonian rheology.

The CMC (carboxymethylcellulose), grade EHV TECH, was produced by Akzo Chemicals B.V. Holland. CMC solutions are power law fluids with very little viscoelasticity.

The xanthan gum was produced by Kelco Oil, USA, under the trade name Xanvis. Xanthan solutions are fluids with pronounced viscoelasticity. It has a non-linear viscosity somewhere between a Bingham plastic and a Herschel-Bulkley fluid.

The weight material used was finely ground powder of barite ($BaSO_4$) with specific density 4.5. However, commercial qualities are normally mixed with other minerals, which may make them somewhat lighter. The barite of quality API/OCMA was delivered by Norbar Minerals and Chemicals, Norway.

Common for the above polymers is that samples from different batches, and even from within the same sac, can differ quite much in their properties. It is thus difficult to produce reproducible results with these chemicals.

Figure 6 shows the measured particle size distribution of a barite sample. Our barite definitely does not satisfy the API specifications⁷, which requires not more than 3.0 % particles larger than 73 μm . For most tests with the three first fluids sifted barite was used, so that the particles were of sizes between 25 and 45 μm .

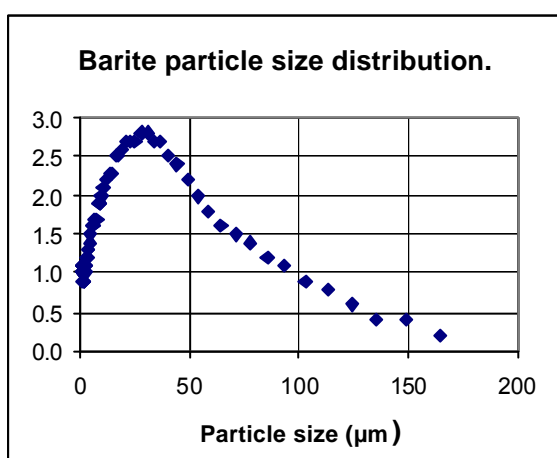

Figure 6. Particle size distribution in barite.

EXAMPLES OF MEASUREMENTS

Below, some examples from the testing on silicon oil and on CMC and xanthan solutions are given.

Silicon oil measurements

Some measurements were performed on silicon oil in order to have some experience with a fluid with a linear rheology. The measurements, however, turned out to be difficult and probably not very accurate. The particles sagged relatively fast in the linear fluid, and some fraction of the particles had normally probably settled out before a measurement could start.

At the ambient temperature of 23.0° C the silicon oil had a viscosity 61 cP. Figure 7 shows the sag measurements on the fluid loaded with 288 g/l barite at different shear stresses.

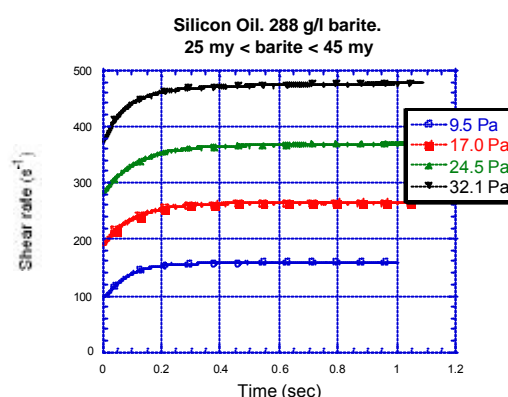

Figure 7. Sag measurements on silicon oil with 288 g/l barite.

Table 1 and Table 2 show the results from measurements on fluids loaded with 228 g/l and 576 g/l barite.

Table 1. Measurements on silicon oil with 288 g/l barite

Shear stress (Pa)	v_s (mm/s)	Initial shear rate (s^{-1})
9.5	0.070	112
17	0.057	179
24.5	0.039	257
32.1	0.058	345

Table 2. Measurements on silicon oil with 576 g/l barite.

Shear stress (Pa)	v_s (mm/s)	Initial shear rate (s^{-1})
16	0.011	95
24	0.010	177
32	0.0064	258
36	0.0073	273

Allowing for low accuracy of the measurements, it may seem that the sagging velocity is independent of shear rate. Stokes formula for the terminal settling velocity of a (single, spherical) barite particle with diameter 35 μm gives 0.042 mm/s. Because of the irregular form of ground particles the settling velocity will be somewhat smaller. The Stokes value is smaller than what is observed in the lighter fluid, but larger than in the heavier one. In the more dense fluid the effect of mutual hindrance may start to dominate.

CMC solution measurements

CMC solutions are power law fluids with the shear rate-shear stress relation:

$$\tau = k\dot{\gamma}^n \quad (4)$$

τ is the shear stress, n the flow index and K the consistency index.

A series of different measurements were performed. The density of the watery solutions in function of added barite was:

Table 3. Densities of watery polymer solutions in function of added barite.

kg/l barite	Density
0.0	1.0
0.288	1.20
0.576	1.39
0.864	1.55
1.152	1.69

Table 4 gives the results from measurements on a 10 g/l CMC solution, loaded with 576 g/l barite. In these measurements the base fluid had the rheology parameters $n = 0.644$ and $K = 0.546 \text{ Pa s}^n$.

Table 4. Measurements on 10 g/l CMC solution with 576 g/l barite.

Sh. str. (Pa)	v_s (mm/s)	Initial shear rate (s^{-1})	S.I.
15	0.013	112	9.1E-06
20	0.020	179	7.5E-06
25	0.037	257	9.3E-06
30	0.060	345	1.0E-05

The sagging velocity increases with shear rate, but the sagging index is fairly stable. One observes that the sagging velocities are similar to or larger than the ones in silicon oil (Table 2). Figure 8 shows a plot from the measurement.

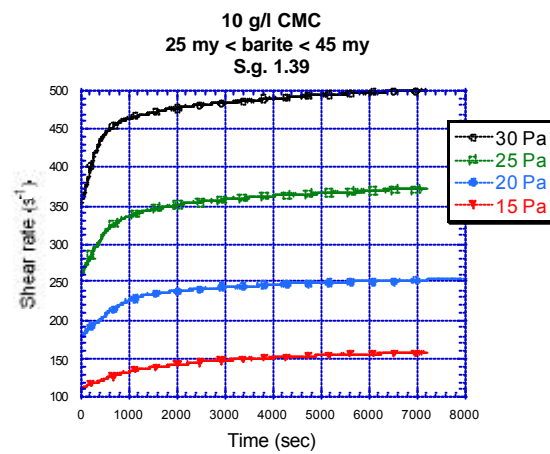

Figure 8. Sag measurements on silicon oil with 576 g/l barite.

A further test series measured the sagging velocity in function of barite loading:

Table 5. Sagging parameters on 10 g/l CMC solution with varying loadings of barite. Constant shear stress of 20 Pa.

Density kg/l	v_s (mm/s)	Initial shear rate (s^{-1})	S.I.
1.20	0.060	307	9.8E-06
1.39	0.022	229	4.9E-06
1.55	0.0092	176	2.6E-06
1.69	0.0037	123	1.5E-06

The sagging index, and thus also the sagging velocity, decrease with increasing barite loading.

The sagging velocity is strongly dependent on particle size. A series of measurements were made with barite sifted to different sizes:

Table 6. Measurements on 10 g/l CMC solution with varying particle sizes. Barite loading 576 g/l. Constant shear stress 25 Pa.

Barite size (μm)	v_s (mm/s)	Initial shear rate (s^{-1})	S.I.
<25	0.0047	184	3.5E-06
25<,<45	0.0079	186	5.7E-06
45<,<75	0.014	187	1.0E-05
75<,<90	0.034	198	2.2E-05

As one may expect, smaller particles sag out slower.

Xanthan solution measurements

Above the shear rate of a few s^{-1} , the viscosity curve of a xanthan solution can be well fitted by the function:

$$t = t_0 + m_0 \dot{g} + A \cdot \exp(-\dot{g} / \dot{g}_0) \quad (5)$$

Thus, at small shear rates it behaves more like a Hershel-Bulkley fluid, and at larger shear

rates like a Bingham fluid. Figure 9 shows a viscosity measurement fitted with the above function. The fit parameters are:

$$\begin{aligned} t_0 &= 4.13 \text{ Pa} \\ \mu_0 &= 0.0128 \text{ Pa s} \\ A &= 1.34 \text{ Pa} \\ \dot{g}_0 &= 38 \text{ s}^{-1} \end{aligned}$$

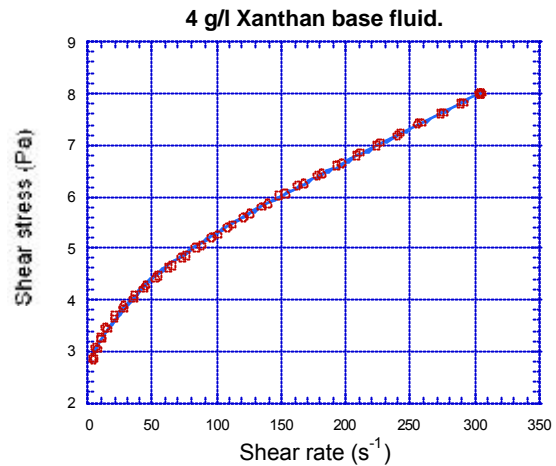

Figure 9. Rheology measurement on a 4 g/l xanthan solution base fluid.

Table 7 shows results from measurements on a xanthan solution with 576 g/l barite loading:

Table 7. Measurements on 4 g/l xanthan solution with varying shear stress. Barite loading 576 g/l.

Sh. str. (Pa)	v_s (mm/s)	Initial shear rate (s^{-1})	S.I.
8	0.0042	94	1.1E-06
10	0.013	183	1.5E-06
11.8	0.020	282	1.3E-06
13	0.030	377	1.4E-06

The sagging index stays fairly constant, in spite of sagging velocity varying by a factor of seven. One also observes the large difference to the sagging index in the similar measurement on the CMC solutions (Table 4). In fluids with

similar viscosity and at similar shear rates, the particles sag out around six times slower in the xanthan solution. Possibly, some effects from the high viscoelasticity of xanthan solutions are here at play. Figure 10 shows the measurements.

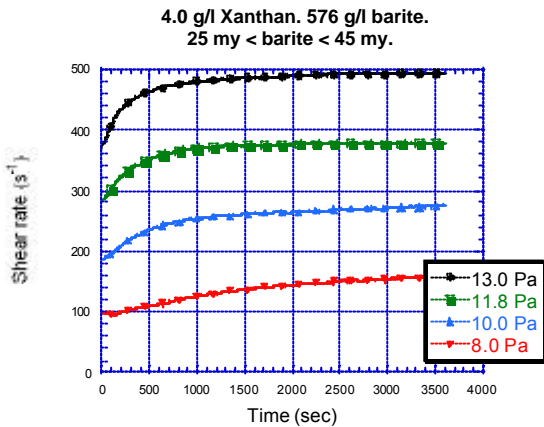

Figure 10. Sag measurement on a 4 g/l xanthan solution loaded with 576 g/l barite.

In Table 8 results from measurements with varying viscosity, i.e. varying content of xanthan are shown.

Table 8. Measurements on varying concentrations of xanthan content. 576 g/l barite loading.

Xanth. conc.	Sh. str. (Pa)	v_s (mm/s)	Initial shear rate (s^{-1})	S.I.
2.0	4.9	0.036	193	2.5E-06
2.7	6.2	0.019	173	1.7E-06
3.3	8.2	0.018	199	1.5E-06
4.0	10.0	0.010	218	9.3E-07

The sagging index is also here fairly constant, in spite of the varying viscosity.

ACKNOWLEDGEMENT

The authors are grateful to ENI-Agip for having supported the research presented in this article.

REFERENCES

1. Jamison, D.E. and Clements, W.R., "A New Test Method to Characterize Setting/Sag Tendencies of Drilling Fluids in Extended Reach Drilling", ASME 1990 Drilling Technology Symposium, PD 27 (1990) 109.
2. Hanson, P.M., Trigg, T.K., Rachal, G. and Zamora, M., "Investigation of Barite "Sag" in Weighted Drilling Fluids in Highly Deviated Wells", SPE 20423, presented at the 1990 SPE Annual Technical Conference and Exhibition, New Orleans, 23–26 September.
3. Jefferson, D.T., "New Procedure Helps Monitor Sag in the Field", paper ASME 91-PET-3, presented at the 1991 Energy Sources Technology Conference And Exhibition, New Orleans, 20-24 January.
4. Bern, P.A., Zamora, M., Slater, K.S. and Hearn, P.J., "The Influence of Drilling Variables on Barite Sag", SPE 36670, presented at the SPE Annual Technical Conference, Denver, Colorado, 6-9 Oct. 1996.
5. Dye, W., Hemphill, T., Gusler, W. and Mullen, G., "Correlation of Ultra-low Shear Rate Viscosity and Dynamic Barite Sag in Invert-Emulsion Drilling Fluids", SPE 56636, presented at the 1999 SPE Annual Technical Conference and Exhibition, Houston, Texas, 3-6 Oct. 1999, and references therein.
6. Saasen, A., "Sag of Weight Materials in Oil Based Drilling Fluids", IADC/SPE 77190, presented at the 2002 IADC/SPE Asia Pacific Drilling Technology Conference, Jakarta, Indonesia, Sept. 9-11.
7. *API Specification for Oil-Well Drilling-Fluid Materials*, API Spec. 13-A, seventh edition, May 1979.